

- [54] **SYSTEM FOR DETERMINING AUTHENTICITY OF AN EXTERNAL MEMORY USED IN AN INFORMATION PROCESSING APPARATUS**
- [75] Inventor: **Katsuya Nakagawa, Kusatsu, Japan**
- [73] Assignee: **Nintendo Co., Ltd., Kyoto, Japan**
- [21] Appl. No.: **812,929**
- [22] Filed: **Dec. 23, 1985**
- [30] **Foreign Application Priority Data**  
 Jun. 24, 1985 [JP] Japan ..... 60-138699  
 Jun. 28, 1985 [JP] Japan ..... 60-143026
- [51] Int. Cl.<sup>4</sup> ..... **G06F 7/58**
- [52] U.S. Cl. .... **364/900; 380/4; 340/825.31**
- [58] **Field of Search** ... 364/200 MS File, 900 MS File, 364/300, 410; 380/4, 25; 235/380, 382, 375; 360/60; 365/52; 273/DIG. 28, 148 B, 150; 434/118, 122, 169; 340/825.3, 825.31, 825.32, 825.34

- [56] **References Cited**
- U.S. PATENT DOCUMENTS**
- |           |         |                  |            |
|-----------|---------|------------------|------------|
| 3,755,641 | 8/1973  | Rackman          | 200/163    |
| 3,772,662 | 11/1973 | Blair            | 360/60     |
| 3,818,190 | 6/1974  | Silverman et al. | 235/382    |
| 3,839,736 | 10/1974 | Hoshall          | 360/132    |
| 3,859,634 | 1/1975  | Perron et al.    | 235/382    |
| 3,934,122 | 1/1976  | Riccitelli       | 340/825.34 |
| 4,095,791 | 6/1978  | Smith et al.     | 273/85 G   |
| 4,117,605 | 10/1978 | Kurland et al.   | 435/319    |
| 4,120,030 | 10/1978 | Johnstone        | 364/200    |
| 4,149,027 | 4/1979  | Asher et al.     | 174/52 R   |
| 4,218,582 | 8/1980  | Hellman et al.   | 178/22     |
| 4,268,715 | 5/1981  | Atalla           | 178/22     |
| 4,281,215 | 7/1981  | Atalla           | 178/22.08  |
| 4,295,039 | 10/1981 | Stuckert         | 235/380    |
| 4,352,492 | 10/1982 | Smith            | 273/1 GC   |
| 4,384,326 | 5/1983  | Devchoudhury     | 364/200    |
| 4,386,773 | 6/1983  | Bronstein        | 273/1 E    |
| 4,430,728 | 2/1984  | Beitel et al.    | 364/900    |
| 4,432,067 | 2/1984  | Nielsen          | 364/900    |
| 4,442,486 | 4/1984  | Mayer            | 364/200    |
| 4,446,519 | 5/1984  | Thomas           | 364/300    |

4,454,594	6/1984	Heffron et al.	364/900
4,458,315	7/1984	Uchenick	364/200
4,462,076	7/1984	Smith, III	364/200
4,471,163	9/1984	Donald et al.	178/22.08
4,492,582	1/1985	Chang et al.	434/169
4,500,879	2/1985	Smith, III et al.	340/739
4,562,306	12/1985	Chou et al.	178/22.08
4,575,622	3/1986	Pellegrini	235/382
4,602,351	7/1986	Shimamura et al.	365/52
4,670,857	6/1987	Rackman	380/4
4,680,731	7/1987	Izumi et al.	364/900
4,757,468	7/1988	Domenik et al.	364/900

**FOREIGN PATENT DOCUMENTS**  
 0114522 1/1984 European Pat. Off.

*Primary Examiner*—Gareth D. Shaw  
*Assistant Examiner*—Jonathan C. Fairbanks  
*Attorney, Agent, or Firm*—Larry A. Jackson

[57] **ABSTRACT**

A system is disclosed for determining the authenticity of computer software when used with a main processor unit. The software is stored in an external memory which may, for example, be in the form of a ROM cartridge, floppy disk or the like. The main processor unit is operated according to a program contained in the external memory. To verify that the external memory is authentic, duplicate semiconductor devices, for example microprocessors, are separately mounted with the external memory and in the main unit, respectively. The semiconductor associated with the external memory device acts as a key device and the duplicate device mounted in the main unit acts as a lock device. The key device and the lock device are synchronized with each other, executing the same arithmetic operation according to the same program. The results of these operations are exchanged between devices, and compared. If the results agree, the external memory is determined to be authentic and the main processor unit is allowed to operate; but if the external memory is determined to be false (not authentic), the main unit is left in a reset (disabled) condition.

13 Claims, 10 Drawing Sheets

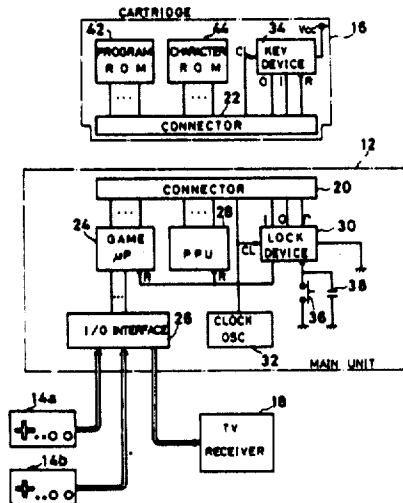

FIG. 1

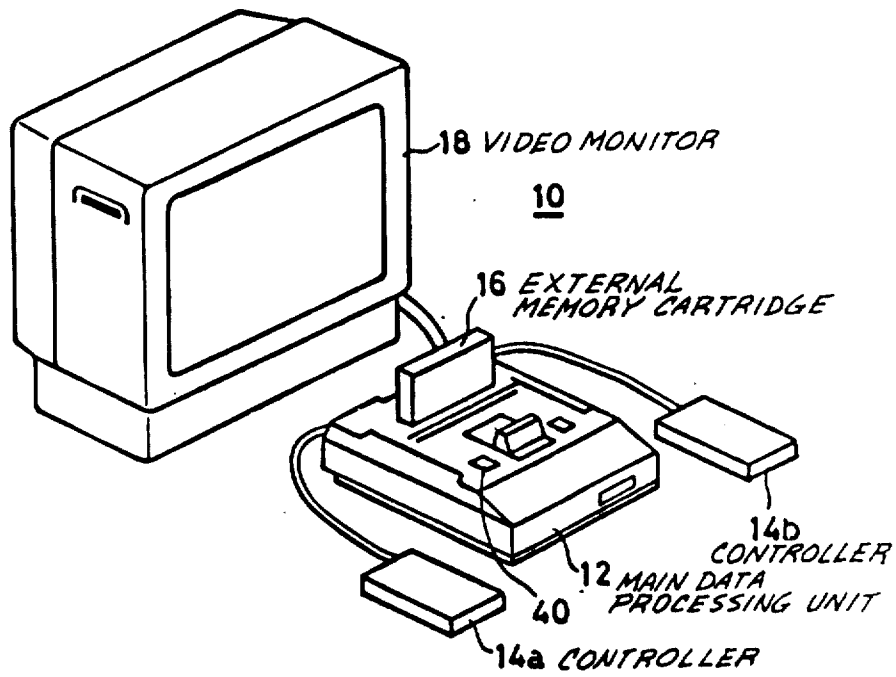

FIG. 6

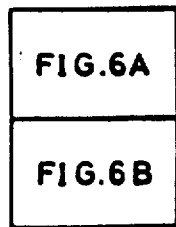

FIG. 7

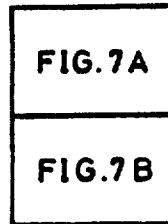

FIG. 2

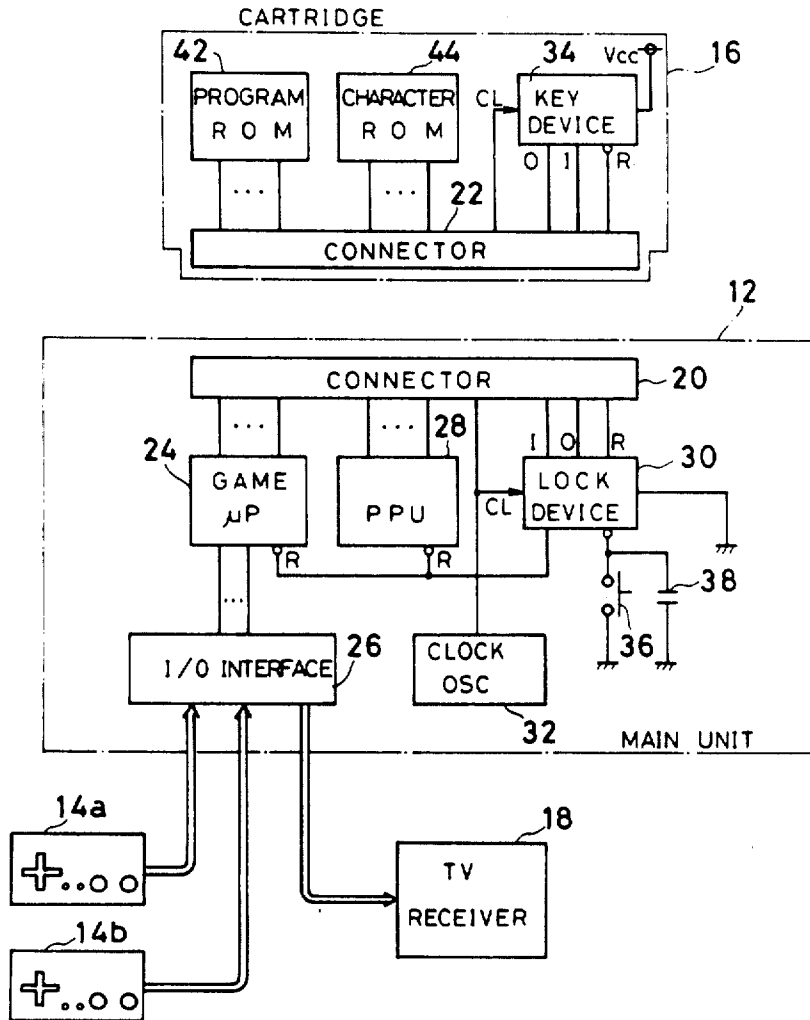

FIG. 3

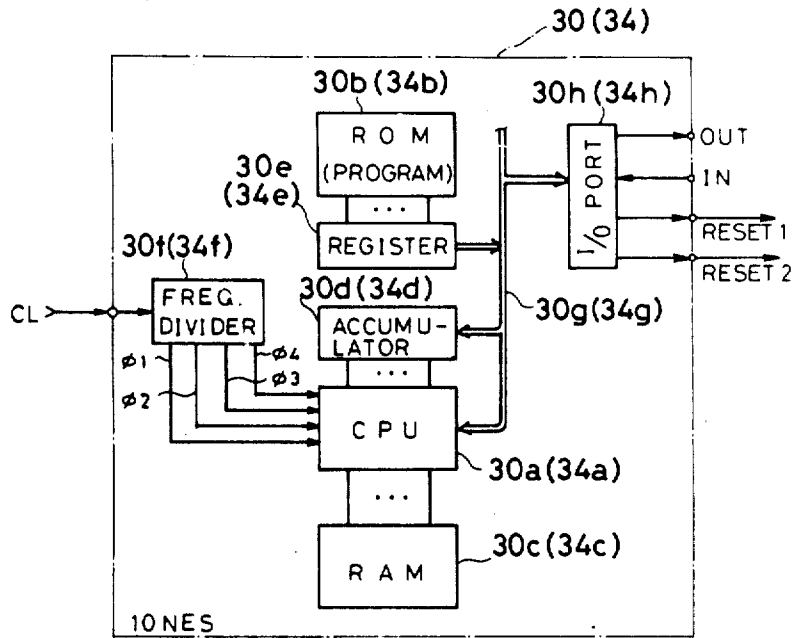

FIG. 4

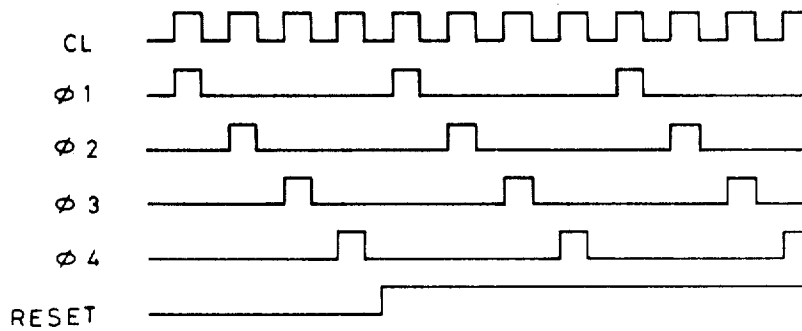

FIG. 5

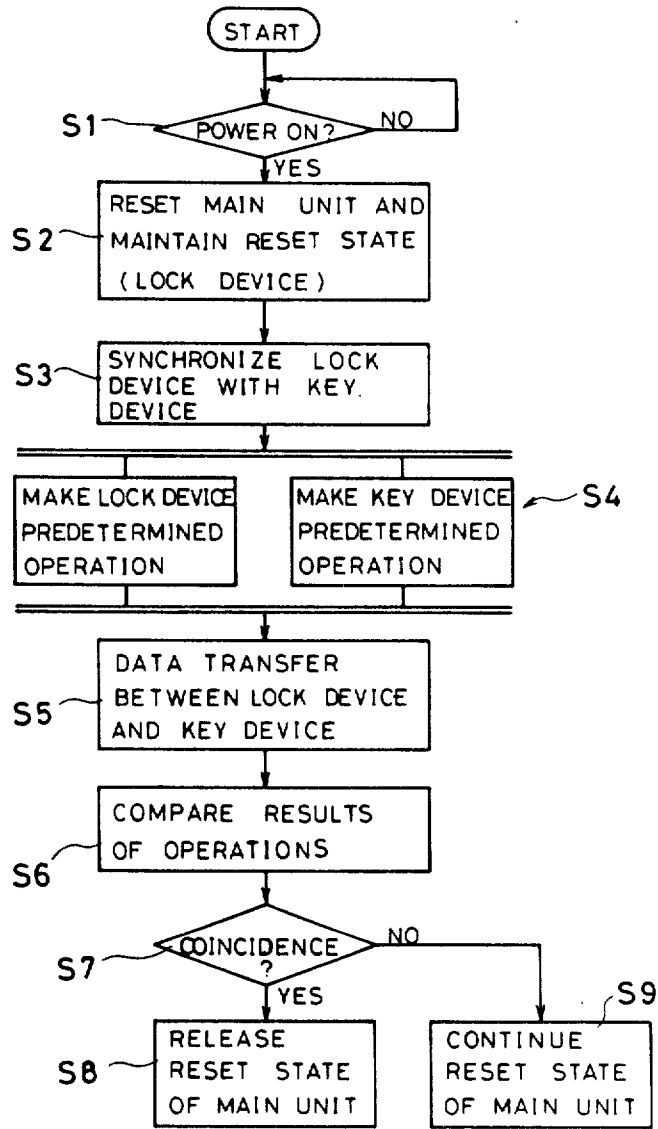

FIG. 6A

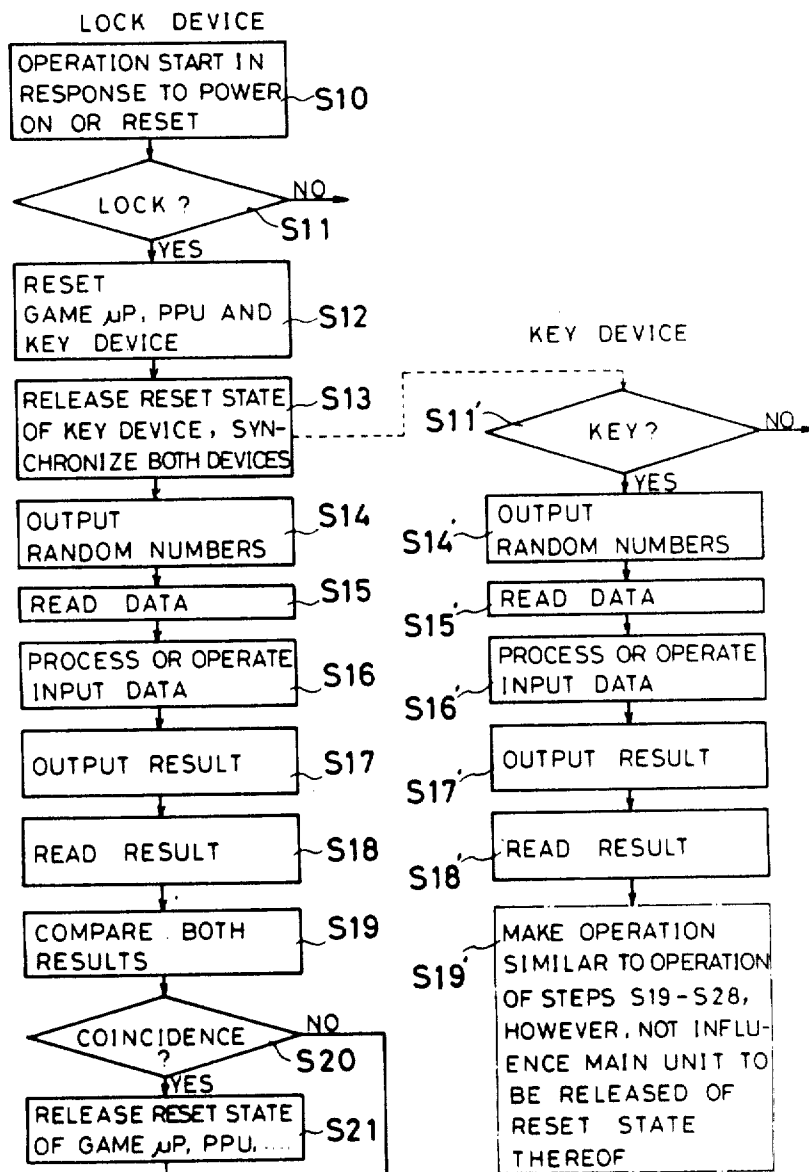

FIG. 6B

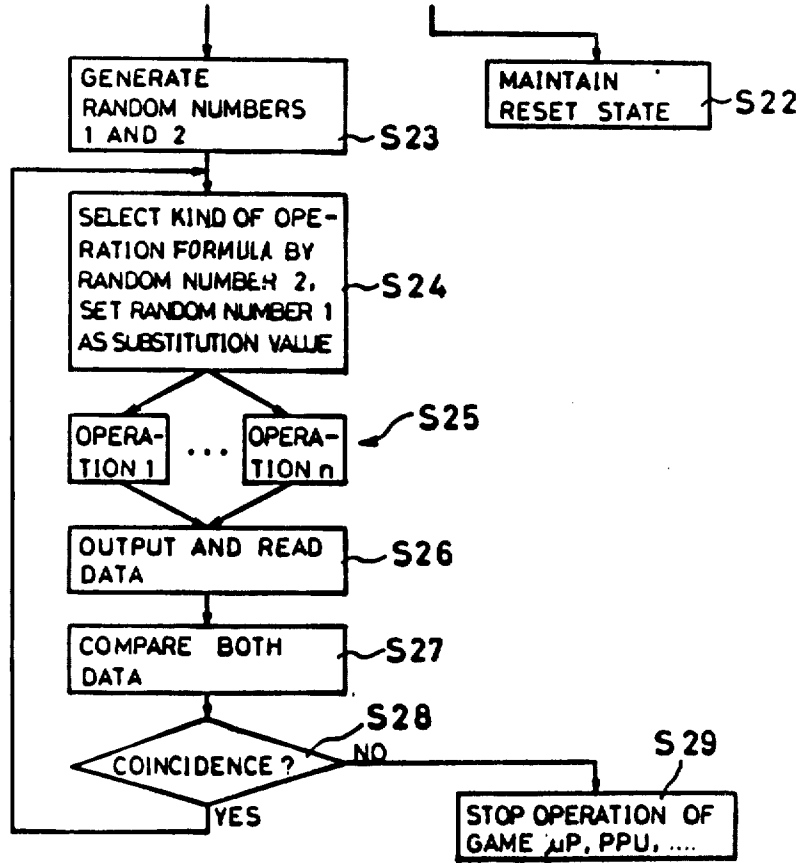

FIG. 7A

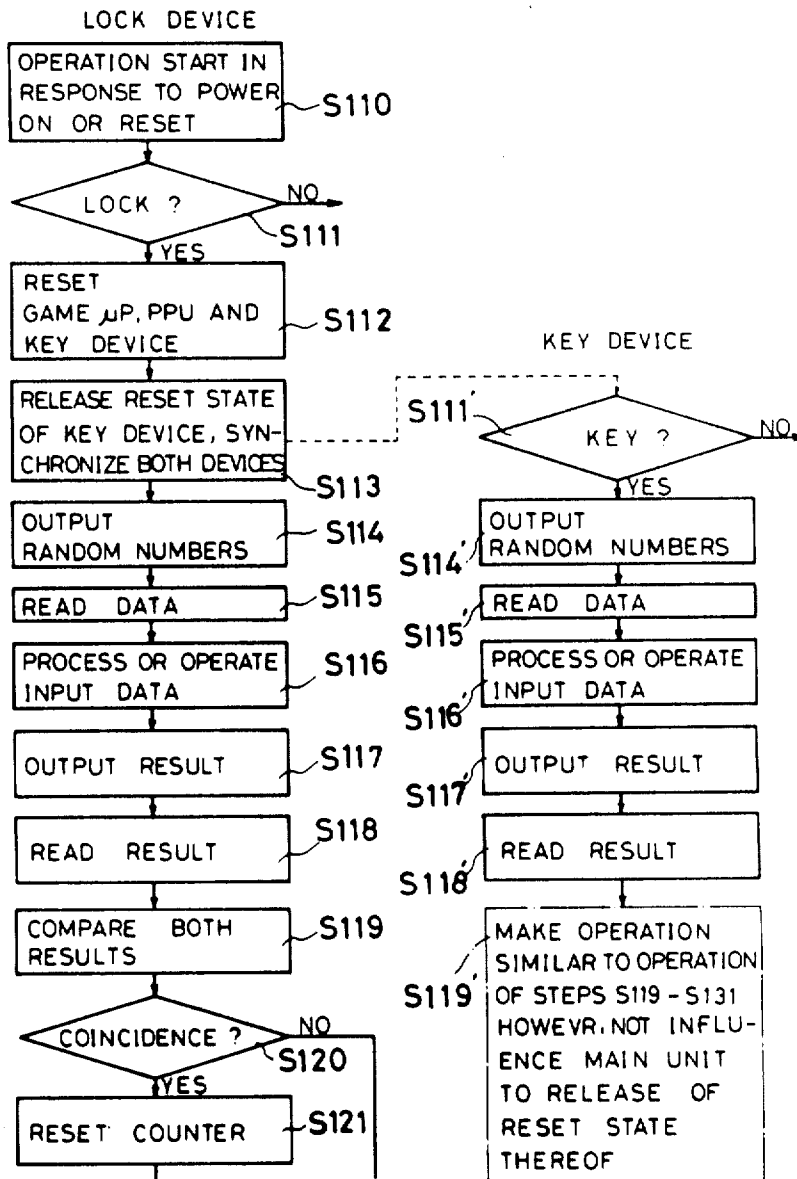



FIG. 7B

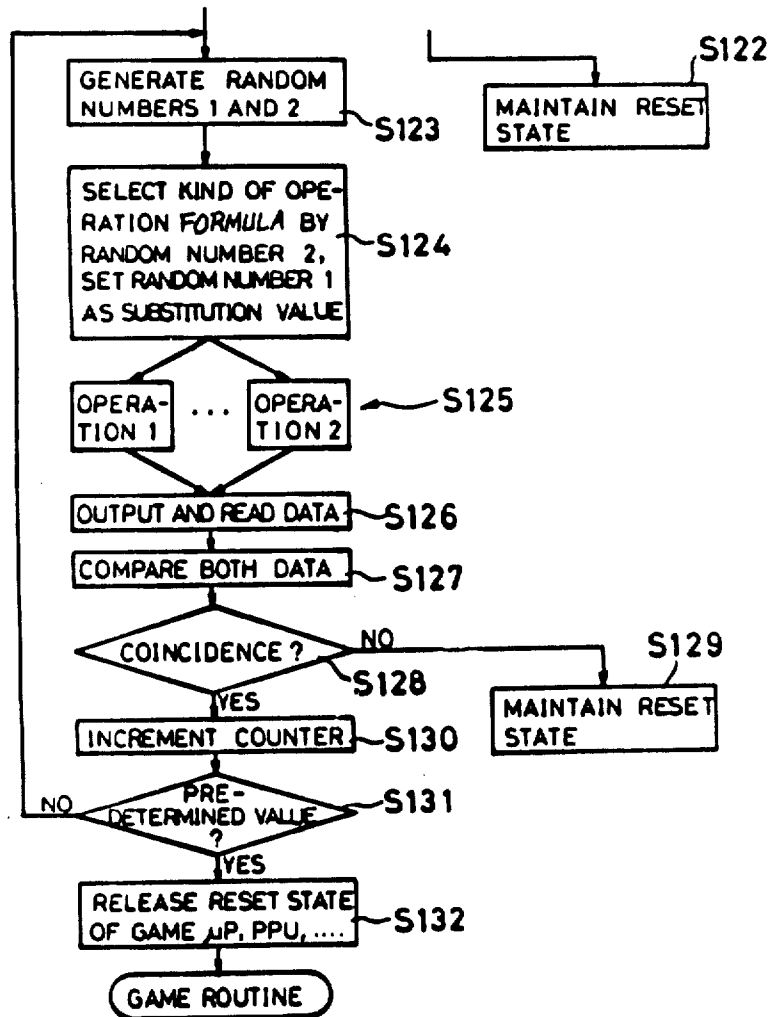

FIG. 8

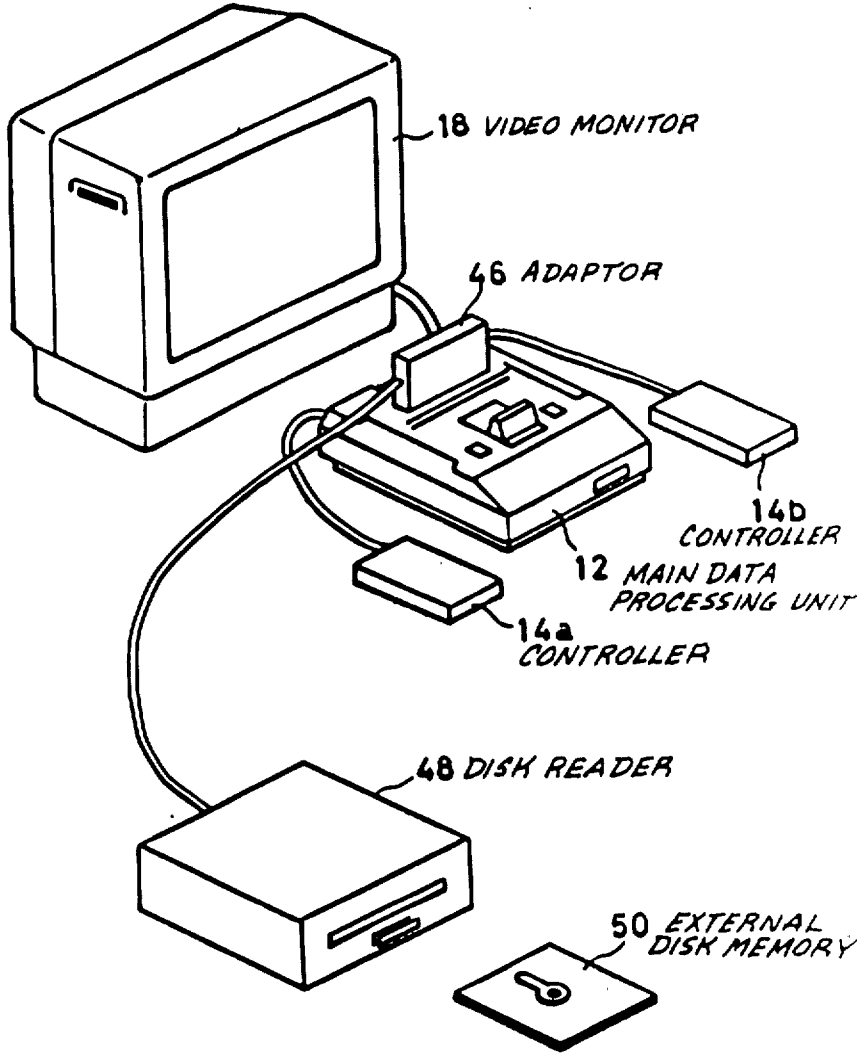

FIG. 9

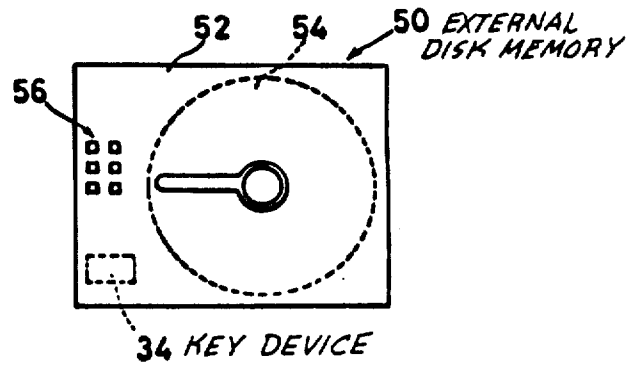
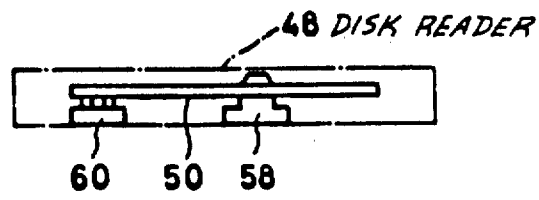

FIG. 10



# SYSTEM FOR DETERMINING AUTHENTICITY OF AN EXTERNAL MEMORY USED IN AN INFORMATION PROCESSING APPARATUS

## BACKGROUND OF THE INVENTION

### 1. Field of the Invention

The present invention relates to a system for determining authenticity of software in an information processing apparatus. More specifically, the present invention relates to a system for determining whether software contained in an external memory, for example, ROM cartridge, floppy disk or the like, is authorized for use with a main processor unit.

### 2. Description of the Prior Art

Conventionally, such information processing apparatus are known wherein an external memory is loaded in a main processor unit and the main unit executes a predetermined program according to software contained in this external memory. One example of such a data processing apparatus is the "Nintendo Entertainment System (trade mark)" manufactured and sold by the assignee of the present application. In that system, a ROM cartridge (external memory) is loaded into the main processor unit, the main unit is connected to a television receiver, and thereby various games can be enjoyed on the screen of the television receiver. A large number of software programs (ROM cartridges) are available for use in such information processing apparatus. However, such authentic software programs are subject to being imitated and counterfeited and it is desirable to provide a system that enables data processing of only authentic program cartridges.

## SUMMARY OF THE INVENTION

Therefore, a principal object of the present invention is to provide a system capable of determining authenticity of software contained in an external memory which is employed together with a main unit in an information processing apparatus. As used herein, authentic means that the software is genuine and authorized for use in the information processing apparatus.

Another object of the present invention is to provide a system for both determining authenticity of software contained in an external memory in an information processing apparatus and enabling data processing in accordance with such software only when it has been determined to be authentic.

An information processing apparatus in which the present invention may be used comprises a main processor unit and an external memory removably connected to this main unit, and wherein the external memory comprises a program (software) for operating the main unit. Associated with external memory is an active device for determining authenticity of the software, and this active device functions as a key device. Another active device is installed in the main unit, and this second active device functions as a lock device. By cooperation of the key device and the lock device, the information processing apparatus is enabled or disabled depending on the authenticity of the external memory which is installed in the main unit, and, if enabled, the apparatus executes a predetermined information processing program according to software contained in the external memory.

In accordance with the present invention, the main processor unit is not enabled unless an authentic external memory (software) is loaded, and therefore the use

of a false (not authentic) external memory can be excluded effectively.

In a preferred embodiment in accordance with the present invention, duplicate semiconductor digital processing devices are used as the key device and the lock device. The two digital devices each execute a predetermined data processing program in synchronism. Then, the lock digital processing device compares the result of its processing with the result of the synchronous processing by the key device. In accordance with this preferred embodiment, the authenticity of the software of the external memory can be determined reliably by a simple arrangement of duplicate digital processing devices added to the main unit and the external memory, respectively.

These objects and other objects, features, aspects and advantages of the present invention will become more apparent from the following detailed description of the embodiments of the present invention when taken in conjunction with accompanying drawings.

## BRIEF DESCRIPTION OF THE DRAWINGS

FIG. 1 is a perspective view showing one example of a video game machine as one embodiment of an information processing apparatus in accordance with the present invention.

FIG. 2 is a block diagram showing a circuit configuration of this embodiment.

FIG. 3 is a block diagram showing a circuit configuration of a lock device used in the systems of FIGS. 1 and 2.

FIG. 4 is a timing chart for explaining operation of FIG. 3 device.

FIG. 5 is a flow chart for explaining the basic operation of the embodiment shown in FIG. 2.

FIGS. 6, 6A, 6B are flow charts for explaining operation of FIG. 2 in further detail.

FIGS. 7, 7A, 7B are flow charts for explaining an alternative operation of a modified embodiment of FIG. 2.

FIG. 8 is a perspective view showing another example of a video game machine as another embodiment of an information processing apparatus in accordance with the present invention.

FIG. 9 is an illustrative view showing one example of a floppy disk used for the FIG. 8 embodiment.

FIG. 10 is an illustrative view showing one example of an apparatus for reading data stored on the floppy disk of the FIG. 8 embodiment.

## DESCRIPTION OF THE PREFERRED EMBODIMENTS

FIG. 1 is a perspective view showing one example of a game machine as one embodiment of the information processing apparatus in accordance with the present invention. Hereinafter, a description of the present invention is made with reference to the game machine shown in FIG. 1. However, it is noted that the present invention is applicable to a variety of information processing apparatus such as a computer, word processor, banking system or the like which employs an external memory, for example, in the form of a cartridge, floppy disk, card or the like.

A game machine 10 comprises a main processor unit 12, and user controllers 14a and 14b are connected to this main unit 12. A cartridge 16 is loaded into the main unit 12 as an external memory. As described in detail

later, the cartridge 16 includes a ROM (Read Only Memory) storing a program written for the game machine. The main unit 12 develops a video signal for the game in response to signals from the controllers 14a and 14b and according to the program contained in the ROM of cartridge 16, and sends this video signal to a television 18. The user watches the picture on the screen of the television 18, operates the controllers 14a and 14b as required, and thereby executes the game programmed in the ROM cartridge 16.

In reference to FIG. 2, a connector 20 is installed in the game machine main unit 12, and this connector 20 is engaged with a connector 22 of the cartridge 16, and thereby the main unit 12 is connected electrically to the ROM contained in cartridge 16.

A game microprocessor 24, for example, the integrated circuit "Z80A" manufactured by Zilog, is mounted on a printed circuit board (not shown) contained in the main unit 12, and the above-described controllers 14a and 14b and TV 18 are connected to this microprocessor 24 through an interface 26.

A PPU (picture processing unit) 28, an active semiconductor device 30 (lock) for determining the authenticity of the external ROM cartridge 16, and a clock oscillator 32 are further included in the main unit 12. The PPU 28 is composed, for example, of an integrated circuit "2C03" manufactured by Nintendo Co. Ltd, Kyoto, Japan, the assignee of the present application, for outputting a video information signal processed by the game microprocessor 24 as a television signal for the TV 18.

The semiconductor device 30 (lock) is in this embodiment provided by a 4-bit microprocessor, for example, the integrated circuit "10NES" manufactured by Nintendo. A like semiconductor device 34 (key) is mounted on a support structure, such as the printed circuit board (not shown), of the cartridge 16. A reset switch 36 is connected to the reset terminal R of the semiconductor device 30 (lock). A reset capacitor 38 is further connected to the reset terminal in parallel with the reset switch 36. The reset capacitor 38 is charged when a power switch 40 (FIG. 1) is turned on, thereby performing a so-called initial reset (power-on-clear) which keeps the semiconductor device 30 in the reset state for a predetermined time.

A ROM 42 for storing the game program (software) and a ROM 44 for generating data defining characters for the game video are mounted on the printed circuit board of the cartridge 16. This printed circuit board of the cartridge 16 is connected electrically to the printed circuit board of the main unit 12 through the two connectors 20 and 22 as described above.

A clock signal CL from the clock oscillator 32 is applied to semiconductor device 30 (lock) and also to the semiconductor device 34 (key) through connectors 20 and 22.

As shown in FIG. 2, a predetermined terminal of the semiconductor device 30 is grounded, while a predetermined terminal of the semiconductor device 34 is connected to a power source Vcc. Thereby, these two semiconductor devices 34 and 30 are differently conditioned to assume the role of a key or a lock, respectively.

In order that the two semiconductor devices 30 and 34 exchange data with each other, the respectively corresponding terminals I, O and R are connected to each other through the connectors 20 and 22. Also, as described above, the common clock CL is applied to

these two semiconductor devices 30 and 34 from the clock oscillator 32. Accordingly, the two semiconductor devices 30 and 34 are operated so that the respective periods and phases of operation are synchronized completely with each other.

Further detailed description is now made of the semiconductor device 30 in reference to FIG. 3. The semiconductor device 34 in the cartridge 16 has the same construction as device 30, and therefore corresponding numbers are shown in parenthesis to avoid duplicate description.

As described above, the semiconductor devices 30 and 34 determine whether the cartridge 16 is authentic or not. The functions of these two semiconductor devices 30 and 34 can be compared to the relationship between a lock and a key. Accordingly, in the following description, the semiconductor device 30 is called a lock device and the semiconductor device 34 is called a key device.

In reference to FIG. 3, the lock device 30 is composed, for example, of a 4-bit microprocessor, comprising a CPU 30a as a data processing means and a ROM 30b and RAM 30c as semiconductor memories. The ROM 30b stores an operating program for the CPU 30a, and two arithmetic routines are contained in this operating program. Thus, a plurality of formulas and data of random numbers for arithmetic computation according to such formulas are contained in one operating program. The operating program also includes a program routine for comparing the computation result of the lock device 30 with the result computed by the key device 34 and vice versa, and for determining whether the results agree. The CPU 30a of lock device 30 functions as a determining means when these comparison and determination routines are executed.

Furthermore, a control program routine for controlling reset or release of reset of the main unit 12 based on the results of the comparison and determination program routines is contained in the operating program.

An accumulator 30d is connected to the CPU 30a. A register 30e is connected to the ROM 30b. This register 30e is for temporarily storing the program data accessed from the ROM 30b. Furthermore, a frequency divider 30f for receiving the clock signal CL from the clock oscillator 32 (FIG. 2) and dividing the frequency thereof is installed in the lock device 30, and the ratio of frequency division of the frequency divider 30f is set, for example, to  $\frac{1}{4}$ . The CPU 30a executes sequential program steps in response to signals of respective phases  $\phi_1$ ,  $\phi_2$ ,  $\phi_3$  and  $\phi_4$  from the frequency divider 30f.

The CPU 30a, the accumulator 30d and the register 30e are connected by a data bus 30g. This data bus 30g is connected to an I/O port 30h, data is outputted from the I/O port 30h to the key device 34, and data from the key device 34 is received through the I/O port 30h. Furthermore, two reset signals RESET 1 and RESET 2 are outputted from the I/O port 30h. The reset signal RESET 1 is given to the key device 34 to reset it. The reset signal RESET 2 is given to the game microprocessor 24 and the PPU 28 which are contained in the main unit 12 to reset them. In order to release the reset states of the key device 34 and the main unit 12, these reset signals RESET 1 and RESET 2 have only to assume the opposite (inverse) state.

Next, a brief description is made on operation of the frequency divider 30f in reference to FIG. 4. As described above, the frequency divider 30f divides the frequency of the clock CL from the clock oscillator 32

by  $\frac{1}{4}$ . Accordingly, four signals  $\phi 1$ ,  $\phi 2$ ,  $\phi 3$  and  $\phi 4$  having different phases respectively are obtained from the frequency divider 30f. These signals  $\phi 1$ - $\phi 4$  are given to the CPU 30a. The CPU 30a performs operations in sequence in synchronism with these four signals  $\phi 1$ - $\phi 4$ . For example, data from the I/O port 30h is read in synchronism with the signal  $\phi 1$ , and predetermined arithmetic operations (data processing) are performed in response to the signals  $\phi 2$  and  $\phi 3$ . Then, data from the I/O port 30h is outputted by the final signal  $\phi 4$ .

Meanwhile, these signals  $\phi 1$ - $\phi 4$  are given also to the key device 34, and accordingly, the lock device 30 and the key device 34 are operated in complete synchronism with each other. Specifically, the lock device 30 and the key device 34 have the same number of steps in their operating programs and have the same architecture, including the same hardware and the same clock, and therefore the respective processing cycles coincide completely.

Next, a brief description is made of the operation of the embodiment with reference to FIG. 5. Afterwards, a more detailed description of the operation is made with reference to FIG. 6.

First, the cartridge 16 is loaded into the main unit 12, and the power switch 40 (FIG. 1) of the main unit 12 is turned on to start the operation (step S1). In the following step S2, the lock device 30 outputs the reset signal RESET 2 and resets the game microprocessor 24 and the PPU 38 comprised in the main unit 12, holding this state. Thus, no game can be played when the main unit 12 is reset.

Next, in step S3, the lock device 30 is synchronized with the key device 34. A method of synchronization thereof is described in reference to FIG. 4. The machine cycle of the lock device 30 is set so that the reset signal RESET 1 given to the key device 34 from the lock device 30 is outputted between signal  $\phi 4$  of certain period of the clock CL and the signal  $\phi 1$  of the next period. Consequently, the signal  $\phi 1$  is first inputted without fail to the key device 34. Consequently, the key device 34 can start operation from the same machine cycle  $\phi 1$  as that of the lock device 30. Thus, in step S3 the lock device 30 is synchronized with the key device 34, and thereafter the respective devices 30 and 34 execute predetermined operations in complete synchronization.

Next, in step S4, predetermined arithmetic operations are performed respectively by the lock device 30 and the key device 34. At this time, the arithmetic operation performed by the lock device 30 and the arithmetic operation performed by the key device 34 are the same. Accordingly, if the cartridge 16 is authentic, the results of the two arithmetic operations performed in this step S4 will be the same.

In step S5, the above-described results of the operations are transferred mutually between the lock device 30 and the key device 34. Then, in step S6, the lock device 30 and the key device 34 compare these two arithmetic operation results respectively. In step S7, if it is determined that these two results coincide (agree, then) in step S8, the lock device 30 releases the reset signals RESET 1 and RESET 2, releasing the reset states of the key device 34 and the main unit 12.

Conversely, in step S7, if it is determined that the results do not coincide, then in step S9, the lock device 30 continues to output the reset signals RESET 1 and RESET 2, and accordingly, the reset states of the key

device 34 and the main unit 12 are continued. The operator cannot play the game in this reset state.

Next, further detailed description of the operation is made with reference to FIG. 6. In reference to FIG. 6, if the cartridge 15 is loaded into the main unit 12 and the power switch 40 (FIG. 1) of the main unit 12 is turned on or the reset switch 36 is turned on, the resetting operation of the lock device 30 is performed, and this lock device 30 starts its operating sequence at step S10.

In the following step S11, the lock device 30 determines whether it functions as the lock or as the key. As explained in FIG. 2, this determination is performed by detecting whether the predetermined terminal is grounded or connected to the power source Vcc. In this case, the lock device 30 is determined to function as the lock, but in the case where the determination indicates a key function, for example, due to wiring error, malfunction or the like, an unstable state takes place and no operations are performed at all.

In step S11, when "YES" is determined, in step S12, the lock device 30 outputs the reset signal RESET 2 so that the main unit 12 cannot execute the game program, and the reset state of the main unit 12 is continued. The game microprocessor 24 and the PPU 28 (FIG. 2) are forced to the reset state and disabled until the reset is released in the later-described step S21. And, in this step S12, the reset signal RESET 1 is also outputted to reset the key device 34.

In the next step S13, the lock device 30 releases the reset state of the key device 34, and synchronizes the two devices 30 and 34 with each other as in the above-described step S3 (FIG. 5). Thereby, the two devices 30 and 34 are synchronized with each other, and thereafter the respective devices execute sequential program steps in complete synchronism.

When the reset state of the key device 34 is released in step S13, the key device 34 determines whether it functions as the lock or as the key in the next step S11'. The determination in this step S11' can be made by detecting whether the predetermined terminal of the key device 34 is grounded or connected to the power source Vcc as in the above-described step S11, an unstable state takes place and no operations are performed at all.

When "YES" is determined in step S11', then the operations in the following step S14' and the steps thereafter are executed.

On the other hand, in the lock device 30, the operations in step S14 and thereafter are executed after the step S13 is executed. Accordingly, in the lock device 30 and the key device 34, the very same operations are performed in synchronism, that is, in coincidence as a function of time.

First, the lock device 30 and the key device 34 output data representing random numbers from the respective program ROMs 30b and 34b (FIG. 3) in step S14 and in step S14'. Output of these random number data is performed using the very same random function. Also, the conditions determining operation of the random function are the same for the two devices 30 and 34. Accordingly, when the cartridge is authentic, the data of random numbers generated in the lock device 30 and the data of random numbers generated in the key device 34 should be the same.

Next, in steps S15 and S15', the lock device 30 and the key device 34 exchange data with each other, and read the data of random numbers generated by the counterpart, respectively. Then, in steps S16 and S16', the de-

vices 30 and 34 perform the predetermined data processes or arithmetic operations based on the data of random numbers inputted from the counterpart. The arithmetic operations formula used for the first arithmetic operation in these steps S16 and S16' is the same in the two devices 30 and 34, and therefore the results of these operations become the same when the inputted data of random numbers are the same. Then, in steps S17 and S17', the lock devices 30 and the key device 34 output the results of arithmetic operations to the counterpart, respectively. Responsively, in steps S18 and S18', the two devices 30 and 34 mutually receive the results of arithmetic operation outputted from the counterpart. In this case, the lock device 30 and the key device 34 perform the same operation at the same timing, and therefore the results of operation from the counterpart are received at the same timing. Accordingly, in this embodiment, both coincidence of the results of arithmetic operations and coincidence of time that results are received are taken into account to determine authenticity of the cartridge.

Next, in step S19, the lock device 30 compares the result of its arithmetic operation against the result of operation produced by the key device 34, determining whether or not they coincide. As a result of this comparison, if "NO" is determined in step S20, the lock device 30 in step S22 holds the reset state of each circuit in the main unit 12, namely, the game microprocessor 24 and the PPU 28. Thereby, the main unit 12 is prevented from executing the game program.

Meanwhile, an alarm may be generated in response to a determination of non-coincidence instead of maintaining a hold of the reset states, or the processing may return to the initial state, namely, the step S11.

As a result of the comparison in step S19, if "YES" is determined in step S20, the lock device 30 releases the reset states of these circuits, namely, the game microprocessor 24 and the PPU 28 in the next step S21.

Subsequently, in step S23, the lock device 30 generates two data groups, a first and a second, of random numbers based on predetermined random function. Then, in step S24, the lock device 30 selects the kind of arithmetic operation formula using the second data of random numbers, and sets the first data of random numbers as the values to be substituted into the arithmetic operation formula. More specifically, in this embodiment,  $n$  (positive integer) kinds of arithmetic operation formulas are set in advance in the arithmetic operation program in the ROM 30b (FIG. 3), and from among these, an arithmetic operation formula is selected in response to the second data of random numbers. Subsequently, in step S25, the selected arithmetic operation is executed using the first and the second data of random numbers.

Operations in these steps S19-S25 are also performed in the same manner at the same timing in the key device 34. Then, the same random function for generating the first and the second data of random numbers as that used for the lock device 30 is also used in the case of key device 34. Also, conditions for the random function for generating the first and the second data of random numbers is the same for the lock device 30 and the key device 34 as described above. Accordingly, if the cartridge 16 is authentic, the same arithmetic operation formula is selected for the two devices 30 and 34, and the results of these arithmetic operations should be the same.

Next, in step S26, the lock device 30 passes the results of the arithmetic operation performed in step S25 to the key device 34, and also receives the results of the arithmetic operation performed by the key device 34. A similar operation is performed in the key device 34. Next, in step S27 and S28, the lock device 30 compares and checks the results of the arithmetic operation by itself against the results of the arithmetic operation received from the key device 34 and determines whether or not they agree, i.e., coincide with each other.

If the cartridge 16 loaded in the main unit 12 is not authentic, the results of the arithmetic operations do not coincide, and therefore, in this case, the lock device 30, in step S29, outputs the reset signal RESET 2, maintaining the game microprocessor 24 and the PPU 28 of the main unit 12 in the reset state to stop their operations.

On the other hand, when the lock device 30 determines that the result of the arithmetic operation by itself and the result of the arithmetic operation received from the key device 34 coincide with each other, processing returns again to step S24, and thereafter the operations in steps S24-S28 are repeated. In other words, in this embodiment, as long as the main unit 12 is operated, the second arithmetic operation program in steps S24-S28 are executed repeatedly, and when a non-coincidence of the results of the arithmetic operations occurs even once, step S29 is executed and operation of the main unit 12 is stopped.

In addition, the same operations as those in steps S26-S29 are performed in the key device 34. However, the key device 34 has no effect on resetting and releasing each circuit of the main unit 12. This is because no reset signal is outputted to the main unit 12 from the key device 34.

As for the operation of the key device 34 corresponding to step S29, since chip-select terminal is normally installed in the ROMs 42 and 44 (FIG. 2), this chip-select terminal may be disabled. When the chip-select terminal is disabled, the game microprocessor 24 and the PPU 28 of the main unit 12 cannot access these ROMs 42 and 44, and therefore continuation of the game operation becomes impossible.

Determination of authenticity of the external memory cartridge can be made only by checking the results of the first arithmetic operations in step S16 and step S16', but also in the above-described embodiment, the second arithmetic operations and determination of the results thereof in steps S24-S28 are performed repeatedly as long as the main unit 12 is operated, and therefore the determination of authenticity of the cartridge 16 can be made nearly certain. Accordingly, in the case where a cartridge containing ROMs that are non-authentic copies of the ROMs 42 and 44 in the cartridge 16 or a cartridge containing ROMs storing similar programs are used, the software protection scheme cannot be defeated unless the same hardware as provided in the key device 34 is employed. Also, by using devices such as custom ICs or the like which are difficult to obtain normally, such a protection can be made more complete.

Thus, the protection of programs (software) contained in the cartridge 16 can be made complete by installing the key device 34 for determining the authenticity of the cartridge 16 and determining how it cooperates with the lock device 30 of the main unit 12, and accordingly any copied or forged cartridge, that is, a cartridge other than an authentic one is blocked from operating in unit 12.

FIG. 7 is a flow chart showing a modified example of FIG. 6. Nearly the same hardware as the embodiment in FIG. 6 is employed in this embodiment, and for this FIG. 7 embodiment, though not illustrated, a counter is formed in the RAM 30c of the lock device 30 and the RAM 34c of the key device 34 (FIG. 3), respectively. Then, by utilizing this counter, the second arithmetic operation is repeated a predetermined number of times set by this counter.

The operations in steps S110-S120 and S111'-119' of this FIG. 7 embodiment are the same as those in steps S10-S20 and S11'-S19' (in FIG. 6), and therefore duplicate description is omitted here.

If a coincidence of the results of the first arithmetic operations is determined in step S120, in FIG. 7 embodiment, the counter formed in the RAM 30c of the lock device 30 is reset in step S121. The second arithmetic operation is executed in the following steps S123-S128 likewise in steps S23-S28 in FIG. 6. Then, if a coincidence of the results of the two arithmetic operations is determined in step S128, the lock device 30 increments the counter (not illustrated) formed in the RAM 30c in the next step S130. Then, in the next step S131, determination is made of whether or not the value of the counter is the predetermined value. If the counted value of the counter does not reach the predetermined value, the lock device 30 repeats steps S123-S130.

Then, if "YES" is determined in step S131, that is, if the second arithmetic operation is repeated by the predetermined number of times, the lock device 30 releases the reset states of the game microprocessor 24 and the PPU 28 of the main unit 12 in step S132 as in step S21 in FIG. 6.

In addition, in the embodiment in FIG. 7, the second arithmetic operation is performed repeatedly by the predetermined number of times in steps S123-S131, wherein the number of times may be one.

If the results of the first arithmetic operations in steps S114-S116 coincide, the main unit 12 is enabled immediately, and thereafter the second arithmetic operation as shown in steps S123-S131 is repeated. When "NO" is determined in step S128 during the repetition, the main unit 12 is disabled, and if non-coincidence does not occur by repeating the second arithmetic operation, thereafter the main unit 12 may remain enabled until the power switch 40 (FIG. 1) of the main unit 12 is turned off.

Furthermore, steps S22 and S29 in FIG. 6 and steps S122 and S129 in FIG. 7 may be modified as follows. Black screen data for wholly blackening the screen of the television receiver 18 and title data for displaying a game title are stored in advance in the ROM 42 of the cartridge 16. Then, in the above-described step S22 or S29 and step S122 or S129, a pulse-reset signal is outputted from the lock device 30, and thereby the black screen and the title screen are displayed repeatedly in alternating fashion. Thereby the operator is informed that the cartridge 16 is not authentic.

In addition, the ROM cartridge 16 is used for an external memory in the above-described embodiment. However, for external memory, a magnetic memory, for example, floppy disk, magnetic card or an optical memory, for example, optical disk or the like may be used in place of cartridge 16.

FIG. 8 is a perspective view showing another embodiment in accordance with the present invention. This embodiment employs a floppy disk for an external memory. In the configuration of FIG. 1 embodiment,

the floppy disk cannot be employed without modification, and therefore in the FIG. 8 embodiment, an adapter 46 is used which has the same shape as that of the cartridge 16 (FIG. 1) and is made attachable and detachable to the main unit 12. A disk reader 48 is connected to this adapter 46. Then, a floppy disk 50 is loaded in this reader 48. Accordingly, the program (software) written in advance to the floppy disk 50 is read by the reader 48, and it is sent to the main unit 12 through the adapter 46.

As shown in FIG. 9, the floppy disk 50 comprises a case 52 and disc-shaped magnetic sheet 54 supported rotatably in the case 52. Then, the key device 34 and an electrode 56 for connecting the key device 34 are formed in the case 52.

As shown in FIG. 9, inside the reader 48 receiving such a floppy disk 50, a disk driver 58 is accommodated and also a contact 60 connected to the electrode 56 is installed. Accordingly, the key device 34 installed in the case 52 of floppy disk 50 is connected to the lock device 30 of the main unit 12 through the electrode 56 and the contact 60.

In the embodiment in FIG. 8, operation is executed following the program as shown in FIG. 6 or 7 by cooperation of the lock device 30 (FIG. 2) comprised in the main unit 12 and the key device 34 in the floppy disk 50, and thereby determination is made whether or not the floppy disk 50 is authentic.

Meanwhile, the lock device 30 (FIG. 2) may be installed in the reader 48, not in the main unit 12. In this case, the reset signal will be given to the main unit 12 from the reader 48.

Furthermore, in the case where a memory means is comprised in the apparatus itself which is connected to the adapter 46, for example, in the case where a sound source apparatus comprising a synthesizer ROM or the like is connected, the key device 34 is installed in the adapter 46, and the operation in FIG. 6 or FIG. 7 may be executed by this key device 34 and the lock device 30 built in the main unit 12.

In addition, in the above-described embodiment, microprocessors are employed for the lock device 30 and the key device 34. However, for these devices 30 and 34, simpler digital arithmetic operation devices may be employed, and further more analog processors may be employed which perform analog processing in place of digital processing. Also, a digital circuit may be employed in either of the lock device 30 and the key device 34 and an analog circuit in the other device.

In the case where the analog circuit is employed, various configurations can be utilized other than the above-described analog processor. For example, determination of the authenticity of the external memory (software) may be performed by a coincidence of frequencies of the clock CL converted by both the lock device and the key device following the same program. Furthermore, pulse signals are outputted from the lock device 30 and the key device 34, and the duty ratio of the pulse signals is converted according to a predetermined program, and thereby authenticity can be determined by a coincidence of the duty ratios. Or, for example, determination may be made by a coincidence of levels of integrations of the same saw-tooth waves, and further deferential may be used. Or, authenticity of the external memory can be determined by determining coincidence of the results of analog processes performed by the two devices.



Although the present invention has been described and illustrated in detail, it is clearly understood that the same is by way of illustration and example only and is not to be taken by way of limitation, the spirit and scope of the present invention being limited only by the terms of the appended claims.

What is claimed is:

1. A system for determining whether a videographics software program is authorized for use in an information processing apparatus, comprising:
  - a main data processor unit for executing a videographics software program;
  - an external memory for storing the videographics software program and for removable connection to said main processor unit, said external memory and main processor unit together constituting the information processing apparatus for executing the videographics software program;
  - a first authenticating processor device associated with said external memory for executing a first predetermined authenticating program to determine the authenticity of said external memory;
  - a second authenticating processor device which is installed in said main data processor unit for executing a second predetermined authenticating program to determine the authenticity of said external memory; and
  - control means for resetting said main data processor unit unless the execution of said first authenticating program by said first processor device exhibits a predetermined relationship to the execution of said second authenticating program by said second processor device.
2. A system in accordance with claim 1, wherein said first and second authenticating processor devices have substantially identical processors.
3. A system in accordance with claim 2, wherein said authenticating processors of said first and second devices each include an analog processing device, and said control means includes means for determining whether the results of executions of said authenticating programs by said first and second processor devices are the same, and thereby exhibit said predetermined relationship.
4. A system in accordance with claim 1, wherein said first and second authenticating processor devices each include a digital microprocessor, and said control means comprises a determining means for determining whether results of said executions of the authenticating programs by said digital microprocessors are the same, and thereby exhibit said predetermined relationship.
5. A system in accordance with claim 4, which further comprises an authenticating program storing means for each of said first and second authenticating processor devices for storing the authenticating program.
6. A system in accordance with claim 5, wherein said microprocessors of said first and second authenticating processor devices are substantially identical, said program storing means provides the same authenticating program to said first and second authenticating processor devices, and said determining means includes means for determining whether or not the results of executing said authenticating program by said substantially identical microprocessors in said first and second devices coincide in time and value.
7. A system in accordance with claim 6, wherein said program storing means comprises a first semiconductor memory including the stored authenticating program

for the microprocessor of said first authenticating processor device, and a second semiconductor memory including the stored authenticating program for the microprocessor of said second authenticating processor device.

8. A system in accordance with claim 7, wherein said second authenticating processor device has associated therewith a clock means for providing the same clock signal to said microprocessors of said first and second authenticating processor devices, and said determining means includes means for determining time coincidence of the results of executing said authenticating program by said first and second processor devices.

9. A system in accordance with claim 7, wherein said stored authenticating program in each of said first and second semiconductor memories include a plurality of at least first and second processing routines, respectively, said first and second authenticating processor devices including means for executing said first and second processing routines, and said determining means include means for determining coincidence of the results of the execution of said first and second routines.

10. A system in accordance with claim 9, wherein said first and second authenticating processor devices repeat the execution of said second routines in accordance with said authenticating program, and said determining means include means for determining whether or not the results of executing said routines coincide every time said second routine is repeated.

11. A system in accordance with claim 10, which further comprises means for counting the number of times that the execution of said second routine by said first and second authenticating processor devices is repeated.

12. A system for determining whether a videographics software program is authorized for use in an information processing apparatus comprising:

- a main data processor unit having a reset control;
  - an external memory unit which is removably connected to said main data processor unit to form the information processing apparatus, said external memory unit storing the software program for controlling processing by said main data processor unit;
  - a first microprocessor mounted with said external memory unit and having a stored authenticating program for execution by said first microprocessor;
  - a second microprocessor mounted in said main data processor unit and having a stored authenticating program for execution by said second microprocessor, said second microprocessor cooperating with said first microprocessor in accordance with said stored authenticating programs to determine whether said external memory unit is authorized; and
  - control means for resetting said reset control of said main data processor unit unless said first and second microprocessors determine by the results of the executions of the authenticating programs that said external memory unit is authorized.
13. A system for determining whether a videographics software program is authorized for use in an information processing apparatus, comprising:
- a main data processor unit for executing a software program;
  - an external memory unit for storing the videographics software program and for removable connection to said main processor unit, said external mem-

13

ory unit and main processor unit together consti-  
tuting the information processing apparatus for  
executing the videographics software program;  
a first separate digital processor device mounted with  
said external memory unit for executing first prede- 5  
termined authenticating program to determine the  
authenticity of said external memory unit, and in-  
cluding a first semiconductor memory for storing  
said first predetermined authenticating program;  
a second separate digital processor device which is 10  
installed in said main data processor unit for ex-  
cuting a second predetermined authenticating pro-  
gram to determine the authenticity of said external  
memory unit, said second digital processor device  
being substantially identical to said first digital 15

14

processor device, and including a second semicon-  
ductor memory for storing said second authenticat-  
ing program;  
clock means in said main data processor unit for pro-  
ducing the same clock signal for said first and sec-  
ond digital processor devices; and  
control means for resetting said main data processor  
unit unless the execution of said first authenticating  
program by said first digital processor device out-  
puts results that coincide in time and sequence with  
the output of results from execution of said second  
authenticating program by said second digital pro-  
cessor device.

\* \* \* \* \*

20

25

30

35

40

45

50

55

60

65